

11. Installation Manual

11.1 20/25/35/46 Class

SAFETY PRECAUTIONS



Read the precautions in this manual carefully before operating the unit.



This appliance is filled with R32.

- The precautions described herein are classified as WARNING and CAUTION. They both contain important information regarding safety. Be sure to observe all precautions without fail.
- Meaning of WARNING and CAUTION notices.

WARNING	Failure to follow these instructions properly may result in personal injury or loss of life.
CAUTION	Failure to observe these instructions properly may result in property damage or personal injury, which may be serious depending on the circumstances.

- The safety marks shown in this manual have the following meanings:

Be sure to follow the instructions.	Be sure to establish an earth connection.	Never attempt.
-------------------------------------	---	----------------

- After completing installation, conduct a trial operation to check for faults and explain to the customer how to operate the air conditioner and take care of it with the aid of operation manual.

WARNING

- Ask your dealer or qualified personnel to carry out installation work. Do not attempt to install the air conditioner yourself. Improper installation may result in water leakage, electric shocks or fire.
- Install the air conditioner according to the instructions given in this manual. Incomplete installation may cause water leakage, electrical shock, or fire.
- Be sure to use only the specified accessories and parts for installation work. Failure to use the specified parts may result in the unit falling, water leakage, electric shocks or fire.
- Install the air conditioner on a foundation strong enough to withstand the weight of the unit. A foundation of insufficient strength may result in the equipment falling and causing injury.
- Electrical work must be performed in accordance with relevant local and national regulations and with instructions in this installation manual. Be sure to use a dedicated power supply circuit only. Insufficiency of power circuit capacity and improper workmanship may result in electric shocks or fire.
- Be sure to use a dedicated power circuit. Never use a power supply shared by another appliance.
- Use a cable of suitable length. Do not use tapped wires or an extension lead, as this may cause overheating, electric shocks or fire.
- Make sure that all wiring is secured, the specified wires are used, and that there is no strain on the terminal connections or wires. Improper connections or securing of wires may result in abnormal heat build-up or fire.
- When wiring the power supply and connecting the wiring between the indoor and outdoor units, position the wires so that the control box lid can be securely fastened. Improper positioning of the control box lid may result in electric shocks, fire or overheating terminals.
- After connecting interconnecting and supply wiring be sure to shape the cables so that they do not put undue force on the electrical covers or panels. Install covers over the wires. Incomplete cover installation may cause terminal overheating, electrical shock, or fire.
- When installation or relocating the air conditioner be sure to bleed the refrigerant circuit to ensure it is free of air, and use only the specified refrigerant (R32). The presence of air or other foreign matter in the refrigerant circuit cause abnormal pressure rise, which may result equipment damage and even injury.
- The installation height from the floor must be over 1.8m.
- If refrigerant gas leaks during installation, ventilate the area immediately.
Toxic gas may be produced if the refrigerant comes into contact with fire.
- After completing installation, check for refrigerant gas leakage.
Toxic gas may be produced if the refrigerant gas leaks into the room and comes into contact with a source of fire, such as a fan heater, stove or cooker.
- During pump-down, stop the compressor before removing the refrigerant piping.
If the compressor is still running and the shut-off valve is open during pump-down, air will be sucked in when the refrigerant piping is removed, causing abnormal pressure in the refrigerant cycle, which may result equipment damage and even injury.
- During installation, attach the refrigerant piping securely before running the compressor.
If the compressor is not attached and the shut-off valve is open when the compressor is run, air will be sucked in, causing abnormal pressure in the freezer cycle, which may result equipment damage and even injury.
- Be sure to earth the air conditioner.
Do not earth the unit to a utility pipe, lightning conductor or telephone earth lead. Imperfect earthing may result in electric shocks.
- Be sure to install an earth leakage breaker. Failure to install an earth leakage breaker may result in electrical shocks, or fire.
- Do not use means to accelerate the defrosting process or to clean, other than those recommended by the manufacturer.
- The appliance must be stored in a room without continuously operating ignition sources (for example: open flames, an operating gas appliance or an operating electric heater).
- Do not pierce or burn.
- Be aware that refrigerants may not contain an odour.
- The appliance must be installed, operated and stored in a room with a floor area larger than $-^* \text{m}^2$ for 20/25/35/46 class.
* Since the maximum refrigerant charge of the models is below 1.84kg, it does not have any limitation for the minimum floor area.
- Comply with national gas regulations.
- When flared joints are reused indoors, the flare part shall be re-fabricated.

CAUTION

- Do not install the air conditioner at any place where there is danger of flammable gas leakage.
In the event of a gas leakage, build-up of gas near the air conditioner may cause a fire to break out.
- While following the instructions in this installation manual, install drain piping to ensure proper drainage and insulate piping to prevent condensation. Improper drain piping may result in indoor water leakage and property damage.
- The temperature of refrigerant circuit will be high, please keep the inter-unit wiring away from copper pipes that are not thermally insulated.

⚠ CAUTION

- Make sure to provide for adequate measure in order to prevent that the outdoor unit be used as a shelter by small animals. Small animals making contact with electrical parts can cause malfunctions, smoke or fire. Please instruct the customer to keep the area around the unit clean.
- Tighten the flare nut according to the specified method such as with a torque wrench. If the flare nut is too tight, it may crack after prolonged use, causing refrigerant leakage.
- Only qualified personnel can handle, fill, purge and dispose of the refrigerant.

ACCESSORIES

Indoor unit (A) - (P)

(A) Mounting plate	1	(G) Indoor unit fixing screws M4 x 12L	2	(N) SSID sticker with release paper (attached to the unit)	1
(B) Mounting plate fixing screws M4 x 25L	7	(H) Insulation tape	1	 * Attach the sticker to the sticker attachment area on the cover page of the operation manual and keep it safe.	
(C) Wireless remote controller	1	(J) Operation manual	1	(P) Refrigerant charge label	1
(D) Remote controller holder	1	(K) Installation manual	1	Outdoor unit (Q)	
(E) Fixing screws for remote controller holder M3 x 20L	2	(L) Deodorizing filter (enzyme blue)	2	(Q) Drain socket assembly (There is on the bottom packing case.)	1
(F) AAA, LR03 (alkaline) dry-cell batteries	2	(M) Screw covers	2	For RXM20/25/35/46 only	

CHOOSING A SITE

- Before choosing the installation site, obtain user approval.

Indoor unit

The indoor unit should be located where:

- The restrictions on installation specified in **INDOOR/OUTDOOR UNIT INSTALLATION DRAWINGS** are met.
- Both air inlet and air outlet have clear paths met.
- The unit is not in the path of direct sunlight.
- The unit is away from sources of heat or steam.
- There is no source of machine oil vapour (this may shorten indoor unit life).

- Cool air is circulated throughout the room.
- The unit is away from electronic ignition type fluorescent lamps (inverter or rapid start type) as these may shorten the remote controller range.
- The unit is at least 1m away from any television or radio set (unit may cause interference with the picture or sound).
- Install at the recommended height (not less than 1.8m)
- No laundry equipment is located.

Wireless Remote Controller

- Do not expose the remote controller to direct sunlight (this will hinder receiving signals from the indoor unit).
- Turn on all the fluorescent lamps in the room, if any, and find the site where remote controller signals are properly received by the indoor unit (within 7m).

INSTALLATION TIPS

1. Removing and installing front panel.

Removal method

- 1) Place your fingers in the indentations on the unit (one each on the left and right sides), and open the front panel until it stops.
- 2) While pushing the left side front panel shaft outward, push up the front panel and remove it. (Remove the right side front panel shaft in the same manner.)
- 3) After removing both front panel shafts, pull the front panel toward yourself and remove it.

Installation method

Align the tabs of the front panel with the grooves, and push all the way in, then close slowly. Push the centre of the lower panel surface firmly to engage the tabs.

2. Removing and installing front grille.

Removal method

- 1) Remove front panel and remove the air filter.
- 2) Remove the lower flap. **Fig.1**
- 3) Remove (M) screw covers (2 pcs.). **Fig.2**
- 4) Remove the front grille fixing screws (3 screws). **Fig.2**
- 5) Remove the service cover fixing screws (1 screw) and remove service cover. **Fig.3**
- 6) In front of the ○○○ mark of the front grille, there are 3 upper hooks. Lightly pull the front grille toward you with one hand, and push down on the hooks with the fingers of your other hand. **Fig.4**

3. How to set the different addresses

When 2 indoor units are installed in one room, the 2 wireless remote controllers can be set for different addresses. Change the address setting of one of the two units. When cutting the jumper be careful not to damage any of the surrounding parts.

- 1) Remove the battery cover on the remote controller and cut the address jumper (J4).
- 2) Press **Temp** and **Mode** at the same time.
- 3) Press **Temp**, select **R**, press **Mode**.
- 4) Press the indoor unit ON/OFF switch while the OPERATION lamp is blinking.

CAUTION

- If setting could not be carried out completely while the OPERATION lamp was blinking, carry out the setting process once again from the beginning.
- After setting is complete, pressing **Mode** for about 5 seconds will cause the remote controller to return to the previous display.

Fig.1 Centre hole, one each on the left and right sides, Lower flap

Fig.2 (M) Screw cover, Insert and then tilt downward

Fig.3 Service cover, M4 x 12L (1 pc.)

Fig.4 Long flat plate wrapped in a cloth

Jumper (J4) ADDRESS

EXIST	1
CUT	2

Indoor unit ON/OFF switch

<When there is no work space because the unit is close to ceiling>

⚠ CAUTION

Be sure to wear protection gloves.

Place both hands under the centre of the front grille, and while pushing up, pull it toward you.

- 1) Push up.
- 2) Pull toward you.

INDOOR/OUTDOOR UNIT INSTALLATION DRAWINGS

NOTE

When flaring pipe end and installing the Indoor unit and the outdoor unit, refer to "3 FLARING THE PIPE END" and "3 REFRIGERANT PIPING" on OUTDOOR UNIT.

INTELLIGENT EYE sensor

CAUTION

- Do not hit or forcefully push the intelligent eye sensor. This can lead to damage and malfunction.
- Do not place large objects near the sensor. Also keep heating units or humidifiers outside the sensor's detection area.

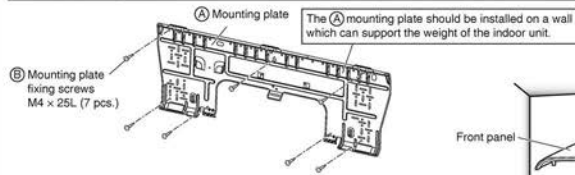

Model	20	25/35	46
Max. allowable piping length	20 m	30 m	30 m
Max. allowable piping height	15 m	20 m	20 m
Additional refrigerant required for refrigerant pipe exceeding 10m in length.	20 g/m		
Min. allowable piping length	2.5 m		
Max. allowable refrigerant charge amount	0.93 kg	1.05 kg	1.60 kg
Gas pipe	O.D. 9.5 mm		O.D. 12.7 mm
Liquid pipe	O.D. 6.4 mm		

- * Be sure to add the proper amount of additional refrigerant. Failure to do so may result in reduced performance.
- ** The suggested shortest pipe length is 2.5m in order to avoid noise from the outdoor unit and vibration (Mechanical noise and vibration may occur depending on how the unit is installed and the environment in which it is used.)
- *** Do not additionally charge refrigerant.

Refrigerant charge label

Please fill in with indelible ink.
 1 the factory refrigerant charge of the product,
 2 the additional refrigerant amount charged in the field and
 3 the total refrigerant charge
 on the refrigerant charge label supplied with the product.
 Affix the refrigerant charge label near the manufacturer's label after filling it out.

The filled out label must be adhered in the proximity of the product charging port.

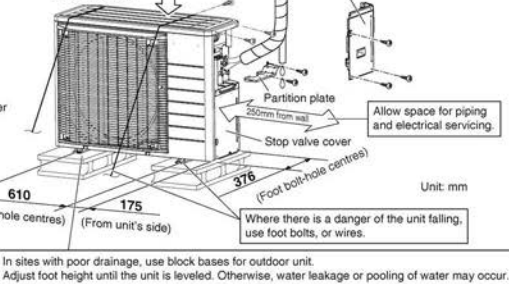
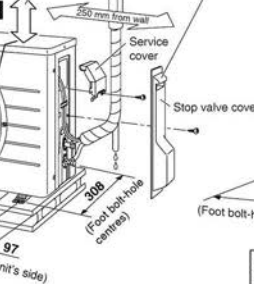
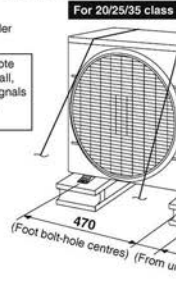
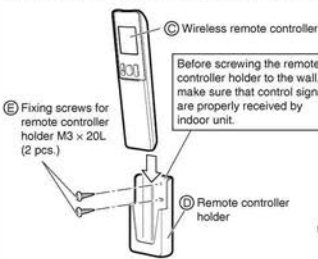
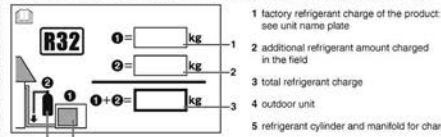

In sites with poor drainage, use block bases for outdoor unit. Adjust foot height until the unit is leveled. Otherwise, water leakage or pooling of water may occur.

- How to attach the indoor unit**
Hook the claws of the bottom frame to the mounting plate.
If the claws are difficult to hook, remove the front grille.
- How to remove the indoor unit**
Push up the marked area (at the lower part of the front grille) to release the claws. If it is difficult to release, remove the front grille.

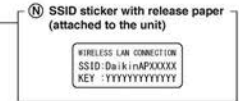
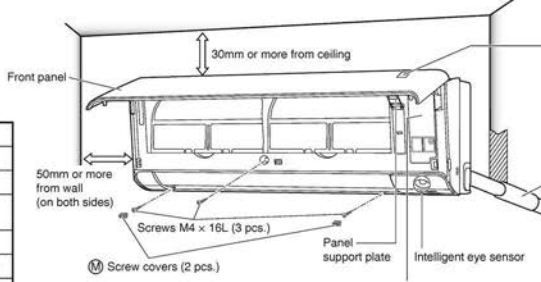
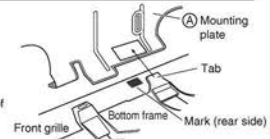

Caulk pipe hole gap with putty.

The flare connection should be installed outdoors.

Cut thermal insulation pipe to an appropriate length and wrap it with tape, making sure that no gap is left in the insulation pipe's cut line.

Wrap the insulation pipe with the finishing tape from bottom to top.

CAUTION
Set the piping length from 2.5 m to 20 m.

Refrigerant piping must be protected from physical damage. Install a plastic cover or equivalent.

Service cover

The service cover is removable.

Opening method

- Remove the service cover screw.
- Pull out the service cover horizontally in the direction of the arrow.
- Pull down.

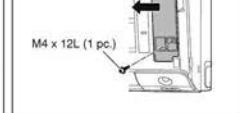

Deodorizing filter (enzyme blue)

Deodorizing filter (enzyme blue) (2 locations)

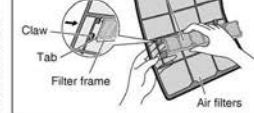

Stop valve cover

- How to remove the stop valve cover.**
Remove the screw on the stop valve cover.
Slide the lid downward to remove it.
- How to attach the stop valve cover.**
Insert the upper part of the stop valve cover into the outdoor unit to install.
Tighten the screws.

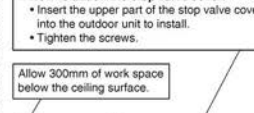

Allow 300mm of work space below the ceiling surface.

Allow 300mm of work space below the ceiling surface.

Allow space for piping and electrical servicing.

Where there is a danger of the unit falling, use foot bolts, or wires.

PRECAUTIONS FOR SELECTING THE LOCATION

⚠ CAUTION

When operating the air conditioner in a low outdoor ambient temperature, be sure to follow the instructions described below.

- To prevent exposure to wind, install the outdoor unit with its suction side facing the wall.
- Never install the outdoor unit at a site where the suction side may be exposed directly to wind.
- To prevent exposure to wind, it is recommended to install a baffle plate on the air discharge side of the outdoor unit.
- In heavy snowfall areas, select an installation site where the snow will not affect the unit.

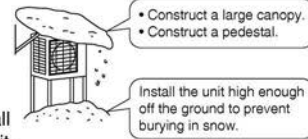

NOTE

Cannot be installed hanging from ceiling or stacked.

- Choose a place solid enough to bear the weight and vibration of the unit, where the operation noise will not be amplified.
- Choose a location where the air discharged from the unit or the operation noise will not cause a nuisance to the neighbors of the user.
- Avoid places near a bedroom and the like, so that the operation noise will cause no trouble.
- There must be sufficient spaces for carrying the unit into and out of the site.
- There must be sufficient space for air passage and no obstructions around the air inlet and the air outlet.
- The site must be free from the possibility of flammable gas leakage in a nearby place.
- Install units, power cords and inter-unit cables at least 3 m away from television and radio sets. This is to prevent interference to images and sounds. (Noises may be heard even if they are more than 3 m away depending on radio wave conditions.)
- In coastal areas or other places with salty atmosphere of sulfate gas, corrosion may shorten the life of the air conditioner.
- Since drain flows out of the outdoor unit, do not place under the unit anything which must be kept away from moisture.

PRECAUTIONS ON INSTALLATION

- Check the strength and level of the installation ground so that the unit will not cause any operating vibration or noise after installed.
- In accordance with the foundation drawing, fix the unit securely by means of the foundation bolts. (Prepare 4 sets of M8 or M10 foundation bolts nuts and washers each which are available on the market.)
- It is best to screw in the foundation bolts, until their length are 20mm from the foundation surface.

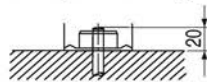

INSTALLATION GUIDELINES

- Where a wall or other obstacle is in the path of outdoor unit's inlet or outlet airflow, follow the installation guidelines below.
- For any of the below installation patterns, the wall height on the exhaust side should be 1200mm or less.

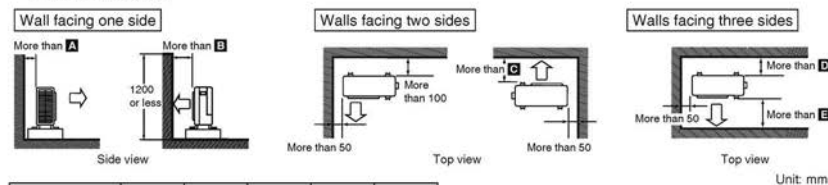

Class	A	B	C	D	E
20/25/35	50	100	150	150	300
46	100	350	350	100	350

■ Important information regarding the refrigerant used

This product contains fluorinated greenhouse gases.

Refrigerant type: **R32**

GWP⁽¹⁾ value: **675**

⁽¹⁾GWP = global warming potential

The refrigerant quantity is indicated on the unit name plate.

INDOOR UNIT

1 INSTALLING THE MOUNTING PLATE

- The mounting plate should be installed on a wall which can support the weight of the indoor unit.
- 1) Temporarily secure the mounting plate to the wall, make sure that the panel is completely level, and mark the boring points on the wall.
- 2) Secure the mounting plate to the wall with screws.

Recommended mounting plate retention spots and dimensions

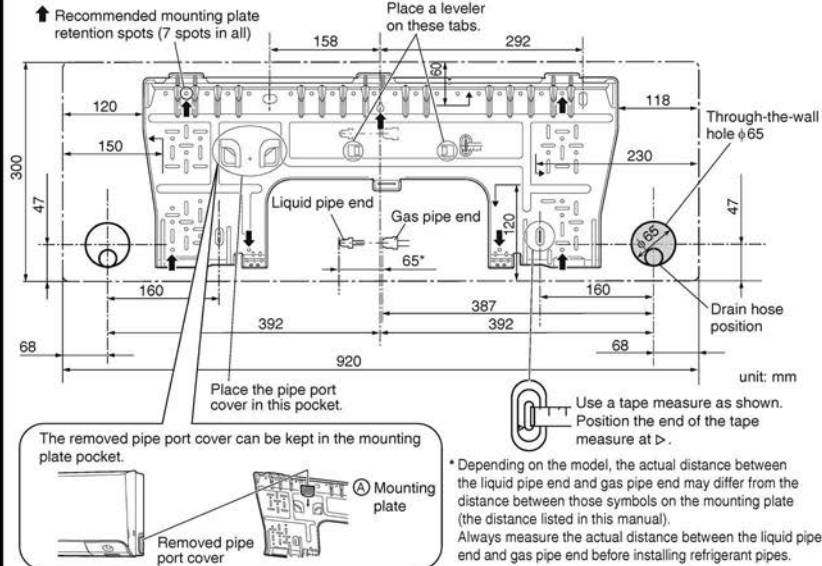

2 BORING A WALL HOLE AND INSTALLING WALL EMBEDDED PIPE

CAUTION

For walls containing metal frame or metal board, be sure to use a wall embedded pipe and wall cover in the feed-through hole to prevent possible heat, electrical shock, or fire.

- Be sure to caulk the gaps around the pipes with caulking material to prevent water leakage.
- Bore a feed-through hole of 65 mm in the wall so it has a down slope toward the outside.
 - Insert a wall pipe into the hole.
 - Insert a wall cover into wall pipe.
 - After completing refrigerant piping, wiring, and drain piping, caulk pipe hole gap with putty.

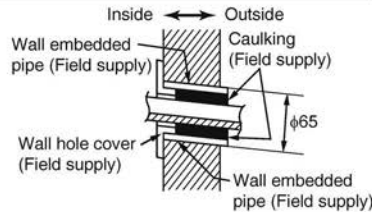

3 INSTALLING INDOOR UNIT

In the case of bending of curing refrigerant pipes, keep the following precautions in mind. Abnormal sound may be generated if improper work is conducted.

- Do not strongly press the refrigerant pipes onto the bottom frame.
- Do not strongly press the refrigerant pipes on the front grille, either.

Right-side, right-back, or right-bottom piping.

- Attach the drain hose to the underside of the refrigerant pipes with an adhesive vinyl tape.
- Wrap the refrigerant pipes and drain hose together with an (H) insulation tape.
- Pass the drain hose and refrigerant pipes through the wall hole, then set the indoor unit on the mounting plate hooks by using the Δ markings at the top of the indoor unit as a guide.

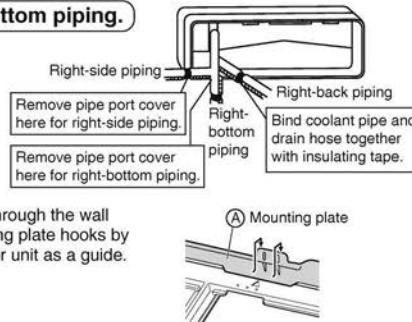

INDOOR UNIT

- 4) Open the front panel, then open the service cover. (Refer to **INSTALLATION TIPS**.)
- 5) Pass the interconnecting wires from the outdoor unit through the feed-through wall hole and then through the back of the indoor unit. Pull them through the front side. Bend the ends of tie wires upward for easier work in advance. (If the interconnecting wire ends are to be stripped first, bundle wire ends with adhesive tape.)
- 6) Press the bottom frame of the indoor unit with both hands to set it on the mounting plate hooks. Make sure that the wires do not catch on the edge of the indoor unit.

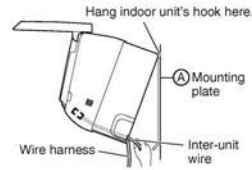

Left-side, left-back, or left-bottom piping.

- 1) Attach the drain hose to the underside of the refrigerant pipes with adhesive vinyl tape.
- 2) Be sure to connect the drain hose to the drain port in place of a drain plug.

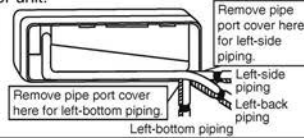

How to switch around the drain plug and drain hose

- 1) Remove the fixing screw and pull out the drain hose.

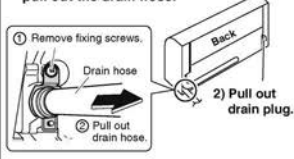

- 3) Switch around the drain hose and drain plug.

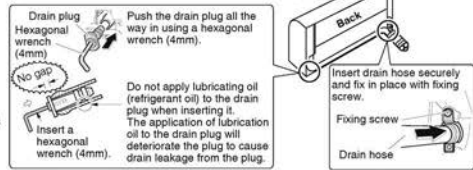

- 3) Shape the refrigerant pipe along the pipe path marking on the mounting plate.
- 4) Pass drain hose and refrigerant pipes through the wall hole, then set the indoor unit on mounting plate hooks, using the Δ markings at the top of indoor unit as a guide.
- 5) Pull in the inter-unit wiring.
- 6) Connect the inter-unit piping.
- 7) Wrap the refrigerant pipes and drain hose together with $\text{\textcircled{C}}$ insulation tape as right figure.
- 8) While exercising care so that the interconnecting wires do not catch indoor unit, press the bottom edge of indoor unit with both hands until it is firmly caught by the mounting plate hooks. Secure indoor unit to the mounting plate with the $\text{\textcircled{C}}$ indoor unit fixing screws (M4 \times 12L).

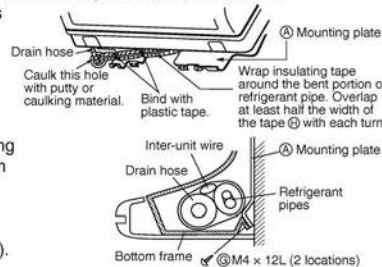

Wall embedded piping.

Follow the instructions given below. Insert the drain hose to this depth so it won't be pulled out of the drain pipe.

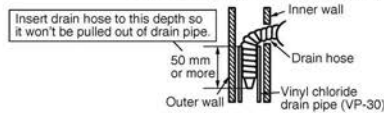

4 WIRING (1)

⚠ WARNING

- Do not use tapped wires, stranded wires, extension cords, or starburst connections, as they may cause overheating, electrical shock, or fire.
- Do not use locally purchased electrical parts inside the product. (Do not branch the power for the drain pump, etc., from the terminal block.) Doing so may cause electric shock or fire.
- Do not connect the power wire to the indoor unit. Doing so may cause electric shock or fire.
- Be sure to install an earth leak detector. (One that can handle higher harmonics.) (This unit uses an inverter, which means that it must be used an earth leak detector capable of handling harmonics in order to prevent malfunction of the earth leak detector itself.)
- Use an all-pole disconnection type breaker with at least 3mm between the contact point gaps.

⚠ CAUTION

When connecting the connection wires to the terminal block using a single core wire, be sure to perform curling. Problems with the installation may cause heat and fires.



- 1) Strip wire ends (20 mm).
- 2) Match wire colours with terminal numbers on indoor and outdoor unit's terminal blocks and firmly screw wires to the corresponding terminals.
- 3) Connect the earth wires to the corresponding terminals.
- 4) Pull wires to make sure that they are securely latched up, then retain wires with wire retainer.
- 5) In case of connecting to an adapter system. Run the remote control cable and attach the S21. (Refer to 5. WHEN CONNECTING AN HA SYSTEM.)
- 6) Shape the wires so that the service cover fits securely, then close service cover.

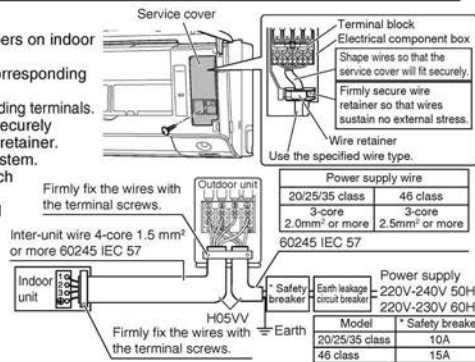

INDOOR UNIT

5 WHEN CONNECTING AN HA SYSTEM

For this procedure, separately sold parts are needed.

- In case there is a work space on the right side of the indoor unit, the procedure can be done while fixing the electrical wiring box.
- Skip to removal of the electrical wiring box if possible, in order to work most efficiently.

(For details, refer to the fixing manual which is attached to the HA board)

- 1) Remove front grille. (see "INSTALLATION TIPS")
- 2) Remove electrical wiring cover. (screw 1 pc.) **Figure. 1, 2**
- 3) Fix HA connection code.
 - Insert HA connection code to HA connector S21 (white)
 - (The color of HA connector S16, which corresponds to JEM-A standard, is blue.)
 - Wire HA connection code as in **Figure. 3**.
- 4) Fix electrical wiring cover box. (screw 1 pc.)
- 5) Fix front grille.

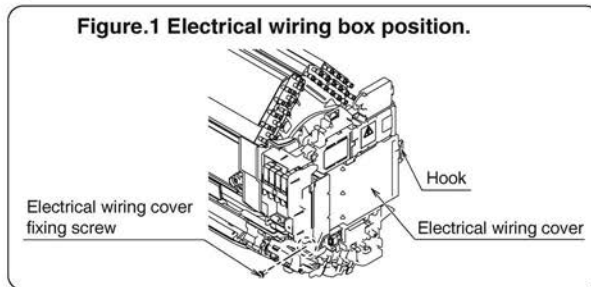

Figure.2 Removing the electrical wiring cover from the indoor unit.

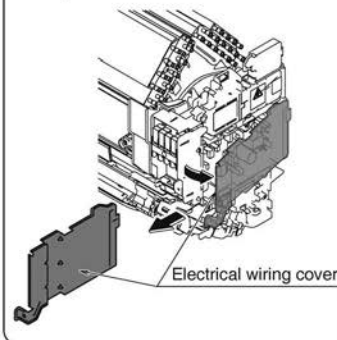
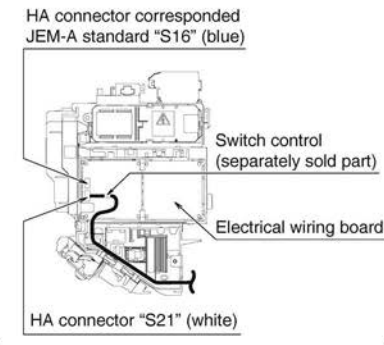

Figure.3 HA connection code wiring method.



* HA system stands for "Home Automation system"

6 DRAIN PIPING

- 1) Connect the drain hose, as described below.
- 3) When drain hose requires extension, obtain an extension hose commercially available. Be sure to thermally insulate the indoor section of the extension hose.

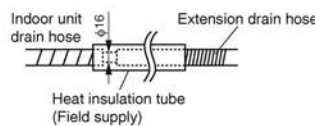
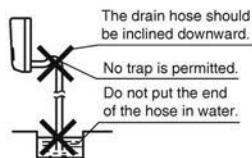

- 2) Remove the air filters and pour some water into the drain pan to check the water flows smoothly.
- 4) When connecting a rigid polyvinyl chloride pipe (diameter 16 mm) directly to the drain hose attached to the indoor unit as with embedded piping work, use any commercially available drain socket (inside diameter 16 mm) as a joint.

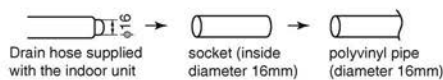
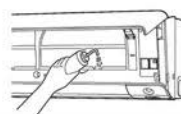



OUTDOOR UNIT

1 INSTALLING OUTDOOR UNIT

- When installing the outdoor unit, refer to "PRECAUTIONS FOR SELECTING THE LOCATION" and the "INDOOR/OUTDOOR UNIT INSTALLATION DRAWINGS".

2 DRAIN WORK (For RXM20/25/35/46 only)

- Use the  drain socket assembly for drainage.
- When attaching the  drain socket to the bottom frame make sure to first connect the drain hose to the drain socket.
- If the drain port is covered by a mounting base or floor surface, place additional foot bases of at least 30mm in height under the outdoor unit's feet.
- In cold areas, do not use a drain hose with the outdoor unit. (Otherwise, the drain water may freeze, impairing heating performance.)

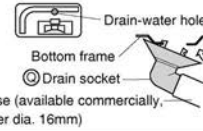

3 FLARING THE PIPE END

⚠ WARNING

- Do not use mineral oil on flared part.
- Prevent mineral oil from getting into the system as this would reduce the lifetime of the units.
- Never use piping which has been used for previous installations. Only use parts which are delivered with the unit.
- Do never install a drier to this R32 unit in order to guarantee its lifetime.
- The drying material may dissolve and damage the system.
- Incomplete flaring may cause refrigerant gas leakage.
- When flared joints are reused indoors, the flare part shall be re-fabricated.

- Cut the pipe end with a pipe cutter.
- Remove burrs with the cut surface facing downward so that the chips do not enter the pipe.
- Put the flare nut on the pipe.
- Flare the pipe.
- Check that the flaring is properly made.



Flaring

Set exactly at the position shown below.

Flare tool for R32	Conventional flare tool	
	Clutch-type	Wing-nut type (Imperial-type)
A	0-0.5mm	1.0-1.5mm
		1.5-2.0mm

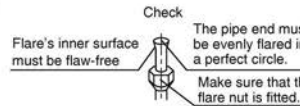

4 REFRIGERANT PIPING

⚠ CAUTION

- Use the flare nut fixed to the unit. (To prevent cracking of the flare nut by aged deterioration.)
- To prevent gas leakage, apply refrigeration oil only to the inner surface of the flare. (Use refrigeration oil for R32.)
- Use torque wrenches when tightening the flare nuts to prevent damage to the flare nuts and gas leakage.

- Align the centres of both flares and tighten the flare nuts 3 or 4 turns by hand. Then tighten them fully with the torque wrenches.
- Refrigerant oil for R32 can also be used for application to the inner flare.

[Apply oil]

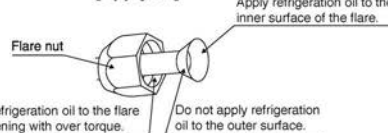

[Tighten]

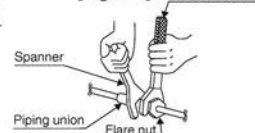

Piping size	Flare nut tightening torque	Valve cap size		
		dimension AA, refer to Fig.1	Valve cap tightening torque	
Gas side	O.D. 9.5mm	32.7-39.9N • m (333-407kgf • cm)	17mm	15.7 ± 1.6N • m (160 ± 16kgf • cm)
	O.D. 12.7mm	49.5-60.3N • m (505-615kgf • cm)	19mm	19.0 ± 1.9N • m (193 ± 20kgf • cm)
	O.D. 15.9mm	61.8-75.4N • m (630-770kgf • cm)	22mm	24.5 ± 3.9N • m (250 ± 40kgf • cm)
Liquid side	O.D. 6.4mm	14.2-17.2N • m (144-175kgf • cm)	27mm	53.9 ± 5.9N • m (550 ± 60kgf • cm)
			32mm	68.6 ± 6.9N • m (700 ± 70kgf • cm)
Service port cap tightening torque		10.7-14.7N • m (110-150kgf • cm)		

1. Cautions on pipe handling.

- Protect the open end of the pipe against dust and moisture.
- All pipe bends should be as gentle as possible. Use a pipe bender for bending.

2. Selection of copper and heat insulation materials.

- When using commercial copper pipes and fittings, observe the following:
- Insulation material: Polyethylene foam
Heat transfer rate: 0.041 to 0.052W/mK (0.035 to 0.045kcal/(mh • °C))
Refrigerant gas pipe's surface temperature reaches 110°C max.
Choose heat insulation materials that will withstand this temperature.

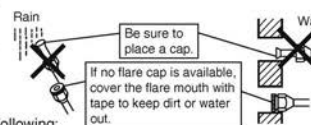

OUTDOOR UNIT

2) Be sure to insulate both the gas and liquid piping and to provide insulation dimensions as below.

	Piping size	Minimum bend radius	Piping thickness	Thermal insulation size	Thermal insulation thickness
Gas side	O.D. 9.5mm	30mm or more	0.8mm (C1220T-O)	I.D. 12-15mm	10mm Min.
	O.D. 12.7mm	40mm or more		I.D. 14-16mm	
	O.D. 15.9mm	50mm or more	1.0mm (C1220T-O)	I.D. 16-20mm	
Liquid side	O.D. 6.4mm	30mm or more	0.8mm (C1220T-O)	I.D. 8-10mm	

3) Use separate thermal insulation pipes for gas and liquid refrigerant pipes.

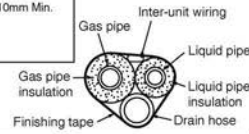

5 PURGING AIR AND CHECKING GAS LEAKAGE

- When piping work is completed, it is necessary to evacuate the air with a vacuum pump and check for gas leakage.

⚠ WARNING

- Do not mix any substance other than the specified refrigerant (R32) into the refrigeration cycle.
- When refrigerant gas leaks occur, ventilate the room as soon and as much as possible.
- R32, as well as other refrigerants, should always be recovered and never be released directly into the environment.
- Use a vacuum pump for R32 exclusively. Using the same vacuum pump for different refrigerants may damage the vacuum pump or the unit.
- Use tools for R32 exclusively.**

- If using additional refrigerant, perform air purging from the refrigerant pipes and indoor unit using a vacuum pump, then charge additional refrigerant.
- Use a hexagonal wrench (4mm) to operate the stop valve rod.
- All refrigerant pipe joints should be tightened with a torque wrench at the specified tightening torque.

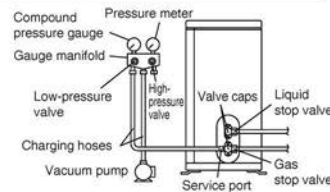

Appearance of the outdoor unit may differ from some models.

- Connect projection side of charging hose (which comes from gauge manifold) to gas stop valve's service port.
- Fully open gauge manifold's low-pressure valve (Lo) and completely close its high-pressure valve (Hi). (High-pressure valve subsequently requires no operation.)
- Do vacuum pumping and make sure that the compound pressure gauge reads -0.1MPa (-760 mmHg)*1.
- Close gauge manifold's low-pressure valve (Lo) and stop vacuum pump. (Keep this state for a few minutes to make sure that the compound pressure gauge pointer does not swing back.)*2.
- Remove covers from liquid stop valve and gas stop valve.
- Turn the liquid stop valve's rod 90 degrees counterclockwise with a hexagonal wrench to open valve. Close it after 5 seconds, and check for gas leakage. Using soapy water, check for gas leakage from indoor unit's flare and outdoor unit's flare and valve rods. After the check is complete, wipe all soapy water off.
- Disconnect charging hose from gas stop valve's service port, then fully open liquid and gas stop valves. (Do not attempt to turn valve rod beyond its stop.)
- Tighten valve caps and service port caps for the liquid and gas stop valves with a torque wrench at the specified torques.

*1. Pipe length vs. vacuum pump running time

Pipe length	Up to 15 m	More than 15 m
Running time	Not less than 10 min.	Not less than 15 min.

*2. If the compound pressure gauge pointer swings back, refrigerant may have water content or a loose pipe joint may exist. Check all pipe joints and retighten nuts as needed, then repeat steps 2) through 4).

6 PUMP DOWN OPERATION

"Pump down" means to collect refrigerant in the outdoor unit.

⚠ CAUTION

- When pressing the switch, do not touch the terminal block. It has a high voltage, and touching it could cause electric shock.
- After closing the liquid stop valve, close the gas stop valve within 3 minutes, then stop the forced cooling operation.

In order to protect the environment, be sure to pump down when relocating or disposing of the unit.

- Remove the valve cap from liquid stop valve and gas stop valve.
- Carry out forced cooling operation following the method below.
 - Using the indoor unit ON/OFF switch
Press the indoor unit ON/OFF switch for at least 5 seconds. (The operation will start.)*1
- After 5 to 10 minutes, close the liquid stop valve with a hexagonal wrench.
- After 2 to 3 minutes, close the gas stop valve and stop forced cooling operation.

Note :

- [1] Forced cooling operation will stop automatically after around 15 minutes. To stop the operation before 15 minutes have elapsed, press the indoor unit ON/OFF switch.

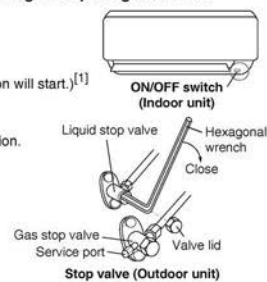

OUTDOOR UNIT

7 WIRING (2)

CAUTION

- When connecting the wires to the terminal block using a single core wire, be sure to perform curling. Problems with the work may cause heat and fires.
- If the stranded wires must be used, make sure to use the round crimp-style terminal for connection to the power supply terminal block. Place the round crimp-style terminals on the wires up to the covered part and secure in place.



For interconnecting wire connections see INDOOR UNIT 4 WIRING (1)

Observe the notes mentioned below when wiring to the power supply terminal block. Precautions to be taken for power supply wiring.

For 20/25/35 class

- Strip the insulation from the wire (20mm).
- Connect the inter-unit wire between the indoor and outdoor units so that the terminal numbers match. Tighten the terminal screws securely. We recommend a flathead screwdriver be used to tighten the screws.
- Pull the wire and make sure that it does not disconnect. Then fix the wire in place with a wire stop.

For 46 class

- Remove the service cover and the partition plate. (Refer to Fig.1)
- Strip the insulation from the wire (20mm).
- Connect the inter-unit wire between the indoor and outdoor units so that the terminal numbers match. Tighten the terminal screws securely. We recommend a flathead screwdriver be used to tighten the screws. (Refer to Fig.2)
- Pull the wire lightly to make sure that it does not disconnect. Then fix the wire in place with the wire retainer.
- After completing the work, reattach the partition plate and the service cover to their original positions. (Refer to "How to attach the partition plate.")

How to attach the partition plate.

- Insert the protrusion of the partition plate into the notch in the metal sheet.
- Slide the partition plate so that the tab on the metal sheet fits into the slit on the partition plate.
- Secure with 2 screws.

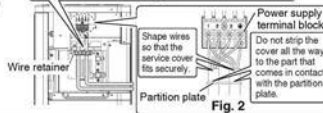
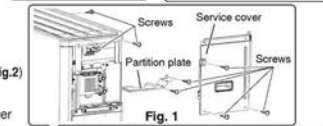
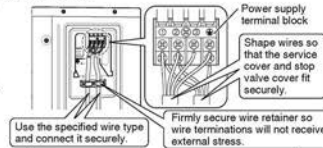
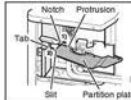

FACILITY SETTING SWITCH (COOLING AT LOW OUTDOOR TEMPERATURE)

This function is designed for facilities such as equipment or computer rooms. It is never to be used in a residence or office where people occupy the space.

CAUTION

- If the outdoor unit is installed where the heat exchanger of the unit is exposed to direct wind, provide a windbreak wall.
- Intermittent noises may be produced by the indoor unit due to the outdoor fan turning on and off when using facility settings.
- Do not place humidifiers or other items which might raise the humidity in rooms where facility settings are being used. A humidifier might cause dew condensation from the indoor unit outlet vent.
- Cutting jumper sets the indoor fan tap to the highest position. Notify the user about this.

- Cutting jumper on the circuit board will expand the operation range down to -15°C . However it will stop if the outdoor temperature drops below -18°C and start back up once the temperature rises again.

- Remove the screws on the side and remove the top plate of the outdoor unit.
- Remove the drip proof cover. (46 class)
- Cut the jumper of the PCB inside.

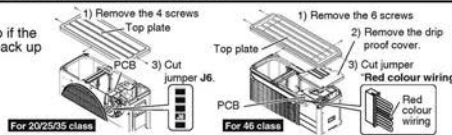

TRIAL OPERATION AND TESTING

- 1-1 Measure the supply voltage and make sure that it is within the specified range.
- 1-2 Trial operation should be carried out in either COOL or HEAT operation. In COOL operation, select the lowest programmable temperature; in HEAT operation, select the highest programmable temperature.
- 1-3 Carry out the trial operation in accordance with the operation manual to ensure that all functions and parts, such as flaps movement, are working properly.
 - For protection, the system disables restart operation for 3 minutes after it is turned off.
 - When trial operation is conducted in the HEAT operation directly after the circuit breaker is turned on, in some cases no air will be output for about 3 to 15 minutes in order to protect the air conditioner.
- 1-4 After trial operation is complete, set the temperature to a normal level (26°C to 28°C in COOL operation, 20°C to 24°C in HEAT operation).
- When operating the air conditioner in COOL operation in winter or HEAT operation in summer, set it to the trial operation mode using the following method.

Trial operation from remote controller

- Press **ON/OFF** to turn on the system.
- Press **Temp**, **Mode**, and **Mode** at the same time.
- Press **Temp**, select "T", and press **Mode** for confirmation.
- Trial operation will stop automatically after about 30 minutes. To stop the operation, press **ON/OFF**.

- Some of the functions cannot be used in the trial operation mode.
- The air conditioner draws a small amount of power in its standby mode. If the system is not to be used for some time after installation, shut off the circuit breaker to eliminate unnecessary power consumption.
- If the circuit breaker trips to shut off the power to the air conditioner, the system will restore the original operation mode when the circuit breaker is turned on again.

TEST ITEMS

Test items	Symptom	Check
Indoor and outdoor units are installed properly on solid bases.	Fall, vibration, noise	
No refrigerant gas leaks.	Incomplete cooling/heating function	
Refrigerant gas and liquid pipes and indoor drain hose extension are thermally insulated.	Water leakage	
Draining line is properly installed.	Water leakage	
System is properly earthed.	Electrical leakage	
The specified wires are used for interconnecting wire connections.	Inoperative or burn damage	
Indoor or outdoor unit's air inlet or air outlet has clear path of air. Stop valves are opened.	Incomplete cooling/heating function	
Indoor unit properly receives remote controller commands.	Inoperative	
The included SSID/KEY sticker (1 pc) is attached to the operation manual, or presented to the user.	Unable to connect to wireless LAN	