



The World Leading Heat Pump Company



HEATING AND COOLING SOLUTIONS

US7

AS SMART, AS IT IS STYLISH

Top of its class and packed with advanced technologies, US7 delivers ultimate comfort with its humidifying, dehumidifying, ventilating and air purification features.

BEST FOR:

- HUMID OR DRY CLIMATE ZONES
- PURIFYING THE AIR IN YOUR HOME
- INTRODUCING OUTSIDE FRESH AIR TO YOUR HOME



INCREDIBLY EFFICIENT

US7 is the first Split Heat Pump in New Zealand to be awarded a 7-star 'Super Efficiency' rating*. It is also packed with advanced technologies and a range of innovative features that distinguishes US7 from every other.



ADVANCED HUMIDIFICATION

Excessively dry air can cause dry skin and a sore throat. Our advanced humidification unit in the outdoor unit draws moisture from outdoor air and distributes this indoors to make you feel warmer and more comfortable.



FRESH AIR SUPPLY

Fresh air is taken from the outside and purified in the Daikin Flash Streamer, ventilating your home with clean, fresh air at the touch of a button.

* 25 Class Model

REVERSE
CYCLE



3.6kW
-TO-
6.3kW
RATED HEATING
CAPACITIES

3
MODELS



DAIKIN
MOBILE CONTROLLER
OPTION



3-AREA INTELLIGENT EYE

Ensures draught free comfort by detecting human movement in left, right and centre zones. If no movement detected for a period of 20 minutes, the heat pump adjusts the set temperature by $\pm 2^{\circ}\text{C}$ to save energy.



POWERFUL DEHUMIDIFICATION

Through intelligent control of the indoor heat exchanger and mixing warmer room air with dehumidified air, US7 cleverly reduces humidity without making your room too cold and uncomfortable.



HEAVY DUTY PURIFICATION

Daikin's flash streamer technology offers heavy duty air purification. The high speed electron discharge destroys bacteria, viruses, mould and allergens at a much higher speed than most conventional air filters, leaving your air safe to breathe.

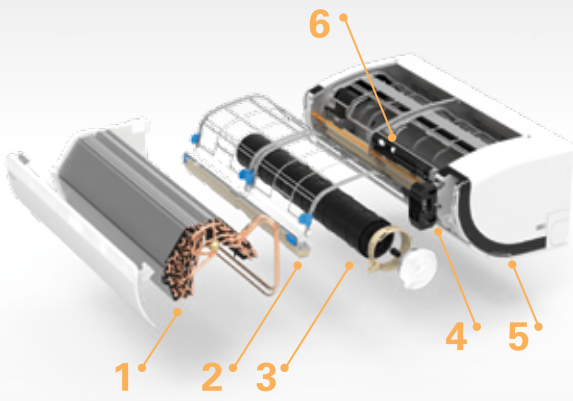

TECHNOLOGY

1. HIGH DENSITY HEAT EXCHANGER

US7's five row heat exchanger utilising Ø5mm copper piping delivers superior cooling and heating performance.

2. AUTOMATIC SELF CLEANING FILTER

An internal brush automatically collects and deposits dust from the air filter to help maintain stable airflow and minimise power consumption.

3. HYPER SAW EDGE FAN

Unique 'Saw Edge' design of the indoor fan rotor delivers superior airflow and quiet operations as low as 19dBA (25-35 Class Model).

4. FLASH STREAMER TECHNOLOGY

Decomposes bacteria and mould absorbed on the filter by ionisation with an advanced plasma electric discharge.

5. NATURAL BREEZE AIRFLOW

By randomly varying airflow and direction, US7 simulates the sensation of a gentle breeze for improved comfort.

6. 2-AREA INTELLIGENT EYE

Ensures draught free comfort by directing airflow either toward or away from you. If no movement is detected for a period of 20 minutes, the heat pump adjusts the set temperature by $\pm 2^{\circ}\text{C}$ to save energy.



Daikin Mobile Controller (Option)

Daikin's Mobile Controller allows you to control your Daikin Split System from anywhere, anytime.

ENERGY RATING 25 CLASS*

COOL ★★★★★★★★

HEAT ★★★★★★★★

SPECIFICATIONS

INDOOR UNIT		FTXZ25NV1B	FTXZ35NV1B	FTXZ50NV1B
OUTDOOR UNIT		RXZ25NV1B	RXZ35NV1B	RXZ50NV1B
Rated Capacity	Cool (kW)	2.5	3.5	5.0
	Heat (kW)	3.6	5.0	6.3
Capacity Range	Cool (kW)	0.6-3.9	0.6-5.3	0.6-5.8
	Heat (kW)	0.6-7.5	0.6-9.0	0.6-9.4
Indoor Airflow Rate (H)	Cool (l/s)	178	202	250
	Heat (l/s)	195	222	240
Indoor Fan Speeds		5 steps, quiet and automatic		
Energy Label/Star Ratings	Cool	7	5.5	3.5
	Heat	7	5.5	4.5
Front Panel Colour		White		
Power Supply		1 phase, 220-240V, 50Hz		
Power Input (Rated)	Cool (kW)	0.42	0.68	1.18
	Heat (kW)	0.62	0.99	1.37
E.E.R./C.O.P	Cool/Heat	5.95/5.81	5.15/5.05	4.24/4.60
A.E.E.R./A.C.O.P	Cool/Heat	5.90/5.77	5.12/5.03	4.23/4.59
Dimensions (HxWxD)	Indoor (mm)	295x798x372		
	Outdoor (mm)	693x795x300		
Weight	Indoor (kg)	15	15	15
	Outdoor (kg)	50	50	50
Compressor Type		Hermetically sealed swing type		
Refrigerant Type		R32		
Max Pipe Length	(m)	10	10	10
Max Level Difference	(m)	8	8	8
Pipe Sizes	Liquid (mm)	6.4	6.4	6.4
	Gas (mm)	9.5	9.5	9.5
Outdoor Operating Range	Cool (°CDB)	-10 to 43		
	Heat (°CWB)	-20 to 18		
Indoor Sound Level (H/SL)	Cool (dBA)	38/19	42/19	47/23
	Heat (dBA)	38/19	42/19	44/24
Outdoor Sound Level (H)	Cool (dBA)	46	48	49
	Heat (dBA)	46	48	50
Outdoor EPA Sound Power Level (H)	Cool (dBA)	59	61	63
	Heat (dBA)	59	61	64

Notes: 1. The rated capacity is measured in accordance with AS/NZS 3823.1.1
 2. The cooling (or heating) output capacity will be reduced below the rated value as the outdoor temperature approaches the maximum (or minimum) outdoor temperature operating range limit.

3. The specifications, designs & information in this flyer are subject to change without notice. Unit colours shown are as close as possible to actual unit colours. Colours depicted in this flyer may vary slightly.

Your Local Daikin Specialist Dealer:



daikin.co.nz