

Non Return Isolation Pressure Reduction Valve Combination, NRI-PRV

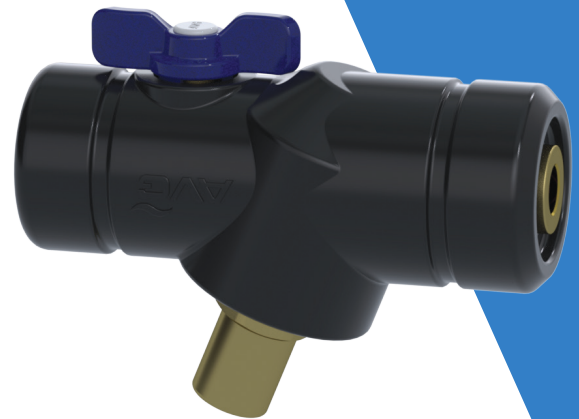
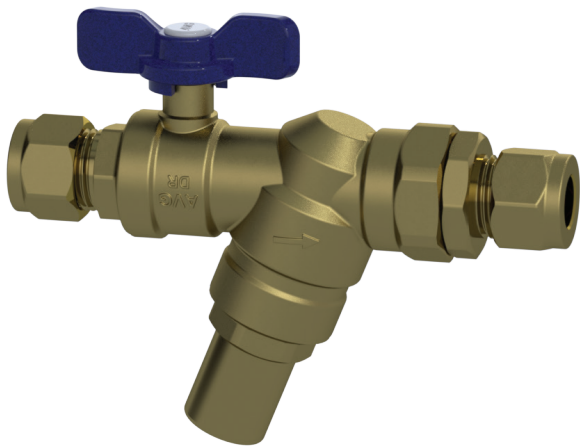

NON RETURN ISOLATION PRESSURE REDUCTION VALVE COMBINATION

A non return isolation pressure reduction valve (NRI-PRV) can be a valuable addition to many piping systems. If the incoming water pressure is too high, this can put unnecessary strain on water heaters, pipe work, plumbing joints, taps and tap washers. It can increase the risk of burst hoses on washing machines, water leaks and possibly magnify any existing water hammer problems.

The valves are factory set at 500 kPa. The down stream pressure is adjustable from 250 to 650 kPa by turning the screw on top. Clockwise to increase pressure and anticlockwise to reduce pressure. For pressure monitoring, there are three gauge ports standard on the body of the valve so that a gauge can be fitted to monitor the upstream and downstream pressure.

The tagging eye has been cast into the NRI-PRV body to allow the valve to be identified and tagged for mechanical service.

NRI-PRV Features

- Adjustable Range 250 – 650 kPa
- Compact design
- Factory set at 500 kPa
- DZR brass valve body
- Internal strainer
- High Flow rate
- Non Return Isolating Valve incorporated
- Valve insulation included



**NRI-PRV-15C
& NRI-PRV-20C**



PERFORMANCE SPECIFICATIONS

Pressure setting range:	250-650 kPa
Factory Setting:	500 kPa
Max. Inlet Pressure:	1600 kPa
Max. Working Temp.:	80°C
Medium:	Water
Complies with:	AS 1357.2

Flow Rate as per Appendix K @ 700 kPa dynamic

NRI-PRV-15C	set pressure 500 kPa	Flow Rate 55 L/Min
	set pressure 250 kPa	Flow Rate 22 L/Min
NRI-PRV-20C	set pressure 500 kPa	Flow Rate 120 L/Min
	set pressure 250 kPa	Flow Rate 30 L/Min

NRI-PRV DIMENSIONS

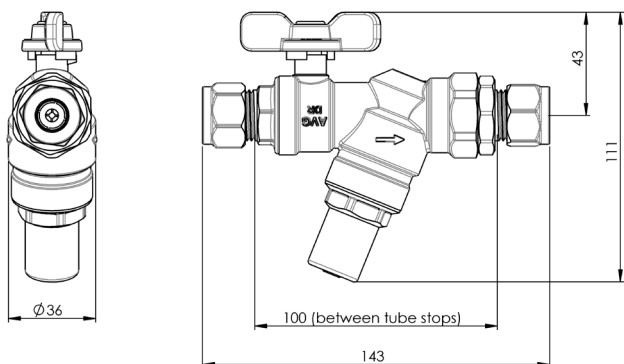

MATERIAL SPECIFICATIONS

Body:	DR Brass
Control Spindle:	DR Brass
Components:	DR Brass
Seals:	EDPM 70
Strainer:	Stainless Steel
Seat:	Stainless Steel 316
Spring:	Stainless Steel

INSTALLATION

- Flush out your lines to remove any debris or dirt particles that may cause the valve to malfunction.
- The pressure reduction valve may be installed horizontally or vertically.
- It is recommended that isolation valves be fitted either side of the pressure reduction valve to assist future maintenance operations.
- The NRI-PRV15 and NRI-PRV20 are protected by an internal stainless steel filter. If the valve is being installed in an environment where fine dirt particles are present it is recommended that a line strainer be fitted upstream of the valve.
- Ensure that the valve is installed in an accessible position for future maintenance operations.
- Install the valve with the arrow on the valve body pointing in the direction of flow.
- For best operation the inlet pressure should be at least 100 kPa higher than the outlet pressure.
- **Suitable for installation below ground in a suitable approved box.**
- If the installation is at risk of water hammer, fit a water hammer arrestor. Do not install PRV's below ground unless the valve is fitted inside a protective box as to prevent damage and corrosion by chemicals in the soil.
- If the pressure setting is important for the protection of equipment fit a pressure relief valve downstream of the valve.

DISCLAIMER: Every care has been taken in the preparation of these instructions, which have been issued as a guide only. Compliance with the requirements of local Authorities is required at all times. These requirements may change from time to time. Always be aware of the local requirements. Subject to any statutory obligations and manufacturers warranties no liability can be accepted for any losses, consequential or otherwise which may arise or be said to have arisen from relying upon the contents of this installation instruction as to the fitness of any particular product for any particular purpose, use or application. The Australian Valve Group Pty Ltd reserves the right to modify designs and specifications and to withdraw and introduce products at any time without notice.